

AG360 Series: AG364

Airless Automatic Manifold Gun.

CE  II 2 G X T6

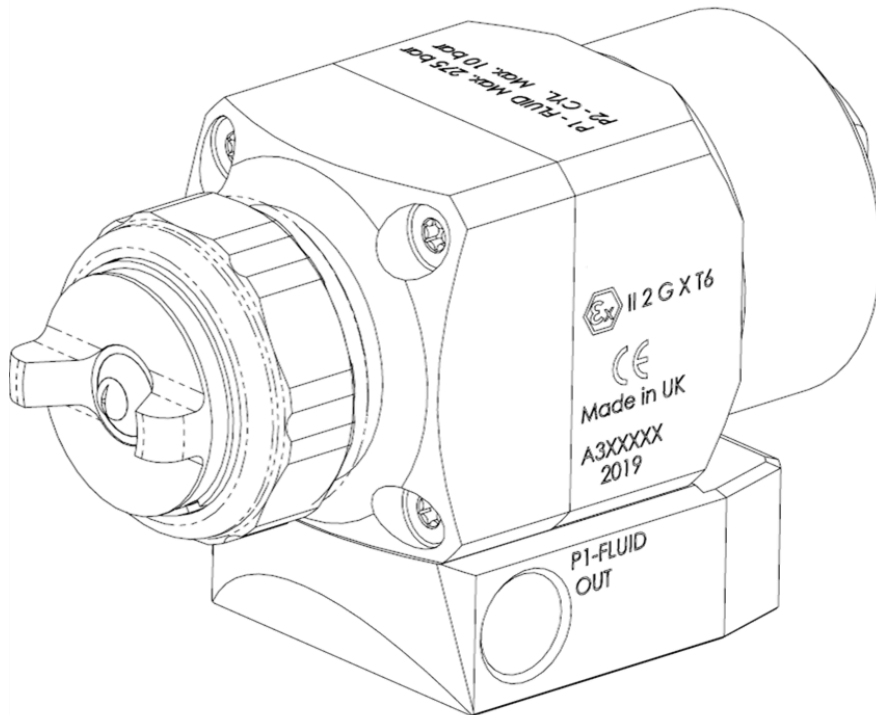

EAC

BINKS
CFT
AG 364
AIRLESS

IMPORTANT! DO NOT DESTROY

It is the Customer's responsibility to have all operators and service personnel read and understand this manual.

Contact your local Carlisle Fluid Technologies representative for additional copies of this manual.

READ ALL INSTRUCTIONS BEFORE OPERATING THIS PRODUCT.

FUNCTIONAL DESCRIPTION

The AG364 Airless gun is designed to be fast change-over, modular construction applicator for spray finishing on machines and fixed mountings.

Intended for most types of general industrial coatings and fine finishing operations, the gun features a stainless steel head suitable for both water based and solvent based applications.

It is mounted on a screw attached low profile stainless steel manifold which can remain in position on the machine while the gun is removed for maintenance or cleaning operations.

The gun is designed as a flexible solution for the modern coating applicator with multiple accessories available to further optimise the process.

SPECIFICATIONS

FLUID AND AIR INLET PRESSURES

P1 = Max Fluid Input Pressure	275 bar [4000 psi]
P2 = Cylinder Air Pressure	4 - 10 bar [58 psi - 145 psi]

ENVIRONMENTAL

Max Ambient Operating Temperature	40°C Nominal [104°F]
-----------------------------------	----------------------

MATERIALS OF CONSTRUCTION

Gun Head and Fluid Passageways	Stainless Steel
Gun Body Material	Anodised Aluminium
Tip Holder Material	Anodised Aluminium
Fluid Needle and Seat Construction	Stainless Steel Tungsten Carbide
Seals and O-Rings	HDPE, FEPM

SCREW TYPE MANIFOLD CONNECTIONS

P1 = Fluid Inlet Size	1/4" NPS
P2 = Cylinder Inlet	1/8" NPS

WEIGHT WITH MANIFOLD

WEIGHT	820g
--------	------

DIMENSIONS WITH MANIFOLD

L x H x W mm	110 x 62 x 44
--------------	---------------

Product Description / Object of Declaration:	AG364
This Product is designed for use with:	Solvent & Waterbased Materials
Suitable for use in hazardous area:	Zone 1/Zone 2
Protection Level:	II 2 G X T6/Ex h II Gb X
Notified body details and role:	Element Materials Technology Rotterdam B.V. (2812)
	Lodging of ATEX Technical file
This Declaration of Conformity / Incorporation is issued under the sole responsibility of the manufacturer:	Binks U.K. Limited, Ringwood Road, Bournemouth, BH11 9LH. UK
Representative authorised to compile the technical file	President @. Binks France SAS 5 Place Pierre Semard, 94130 Nogent sur Marne , Paris, France

EU Declaration of Conformity



This Declaration of Conformity / Incorporation is issued under the sole responsibility of the manufacturer:

Machinery Directive 2006/42/EC

ATEX Directive 2014/34/EU

by complying with the following statutory documents and harmonised standards:

EN ISO 12100:2010 Safety of Machinery - General Principles for Design

BS EN 1953:2013 Atomizing and spraying equipment for coating materials - Safety requirements

EN ISO 80079-36:2016 Explosive Atmospheres- Part 36:Non Electrical equipment for explosive atmospheres-Basic methods and requirements.

EN ISO 80079-37:2016 Explosive Atmospheres- Part 37: Non Electrical equipment for explosive atmospheres - protection by methods "c", "b" and "k".

EN 1127-1:2019 Explosive atmospheres - Explosion prevention - Basic concepts

Providing all conditions of safe use / installation stated within the product manuals have been complied with and also installed in accordance with any applicable local codes of practice.

Signed for and on behalf of

Binks U.K. Ltd:

Document Part No.

. EN

F. A. Sutter

Executive President: Engineering and Operations, Shoreview, MN, 55126. USA

09/04/25

Product Description / Object of Declaration:	AG364
This Product is designed for use with:	Solvent & Waterbased Materials
Suitable for use in hazardous area:	Zone 1/Zone 2
Protection Level:	II 2 G X T6/Ex h II Gb X
Approved body details and role:	Element Materials Technology Warwick Ltd. UK. (0891)
	Lodging of UKEX Technical file
This Declaration of Conformity / Incorporation is issued under the sole responsibility of the manufacturer:	Binks U.K. Limited, Ringwood Road, Bournemouth, BH11 9LH. UK

UKCA Declaration of Conformity

**UK
CA**



This Declaration of Conformity / Incorporation is issued under the sole responsibility of the manufacturer:

Supply of Machinery (Safety) Regulations 2008

Equipment and Protective Systems Intended for use in Potentially Explosive Atmospheres Regulations 2016

by complying with the following statutory documents and designated standards:

BS EN ISO 12100:2010 Safety of Machinery - General Principles for Design

BS EN 1953:2013 Atomizing and spraying equipment for coating materials - Safety requirements

BS EN ISO 80079-36:2016 Explosive Atmospheres- Part 36:Non Electrical equipment for explosive atmospheres-Basic methods and requirements.

BS EN ISO 80079-37:2016 Explosive Atmospheres- Part 37: Non Electrical equipment for explosive atmospheres - protection by methods "c", "b" and "k".

BS EN 1127-1:2019 Explosive atmospheres - Explosion prevention - Basic concepts

Providing all conditions of safe use / installation stated within the product manuals have been complied with and also installed in accordance with any applicable local codes of practice.

Signed for and on behalf of Binks

U.K. Ltd:



Document Part No.

. EN

F. A. Sutter

Executive President: Engineering and Operations, Shoreview, MN, 55126. USA

09/04/2025

 WARNING	 CAUTION	NOTE
Hazards or unsafe practices which could result in severe personal injury, death or substantial property damage.	Hazards or unsafe practices which could result in minor personal injury, product or property damage.	Important installation, operation or maintenance information.

 **WARNING**

Read the following warnings before using this equipment.



SOLVENTS AND COATING MATERIALS. Can be highly flammable or combustible when sprayed. Always refer to the coating material supplier's instructions and safety sheets before using this equipment.



INSPECT THE EQUIPMENT DAILY. Inspect the equipment for worn or broken parts on a daily basis. Do not operate the equipment if you are uncertain about its condition.



READ THE MANUAL. Before operating finishing equipment, read and understand all safety, operation and maintenance information provided in the operation manual. Users must comply with all local and national codes of practice and insurance company requirements governing ventilation, fire precautions, operation and house-keeping of working areas.



EQUIPMENT MISUSE HAZARD. Equipment misuse can cause the equipment to rupture, malfunction or start unexpectedly and result in serious injury.



FIRE AND EXPLOSION HAZARD. Never use 1,1,1-Trichloroethane, Methylene Chloride, other Halogenated Hydrocarbon solvents or fluids containing such solvents in equipment with aluminium wetted parts. Such use could result in a serious chemical reaction, with the possibility of explosion. Consult your fluid suppliers to ensure that the fluids being used are compatible with aluminium parts.



GLOVES. Must be worn when spraying or cleaning the equipment.



WEAR SAFETY GLASSES. Failure to wear safety glasses with side shields could result in serious eye injury or blindness.



STATIC CHARGE. Fluid may develop a static charge that must be dissipated through proper grounding of the equipment, objects to be sprayed and all other electrically conductive objects in the dispensing area. Improper grounding or sparks can cause a hazardous condition and result in fire, explosion or electric shock and other serious injury.



WEAR RESPIRATOR. The use of respiratory protective equipment is recommended at all times. The type of equipment must be compatible with the material being sprayed.



TOXIC VAPOURS. When sprayed, certain materials may be poisonous, create irritation, or are otherwise harmful to health. Always read all labels, safety sheets and follow any recommendations for the material before spraying. If in doubt contact your material supplier.



NEVER MODIFY THE EQUIPMENT. Do not modify the equipment unless the manufacturer provides written approval.



LOCK OUT / TAG-OUT. Failure to de-energise, disconnect, lock out and tag-out all power sources before performing equipment maintenance could cause serious injury or death.

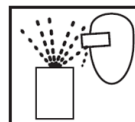

PROJECTILE HAZARD. You may be injured by venting liquids or gases that are released under pressure, or flying debris.



NOISE LEVELS. The A-weighted sound level of pumping and spray equipment may exceed 85 dB(A) depending on equipment settings. Actual noise levels are available on request. It is recommended that ear protection is worn at all times while equipment is in use.



PRESSURE RELIEF PROCEDURE. Always follow the pressure relief procedure in the equipment instruction manual.



KNOW WHERE AND HOW TO SHUT OFF THE EQUIPMENT IN CASE OF AN EMERGENCY.



HIGH PRESSURE CONSIDERATION. High pressure can cause serious injury. Relieve all pressure before servicing. Spray from the gun, hose leaks or ruptured components can inject fluid into your body and cause extremely serious injury.



OPERATOR TRAINING. All personnel must be trained before operating finishing equipment.

IT IS THE RESPONSIBILITY OF THE EMPLOYER TO PROVIDE THIS INFORMATION TO THE OPERATOR OF THE EQUIPMENT.

AG364 PART NUMBER

PART No.	DESCRIPTION
AG364-0000-S	Spray gun with non-recirculation manifold
AG364-0000-T	Spray gun with recirculation manifold

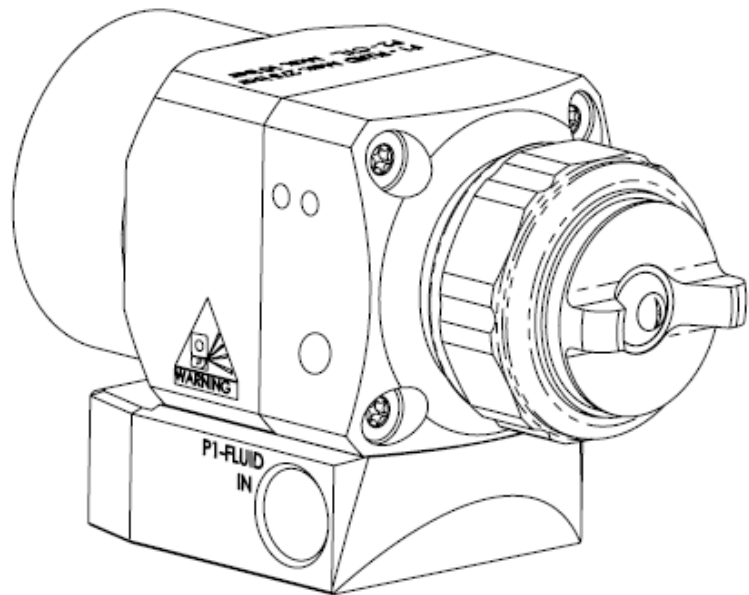

FOR MACHINE MOUNTING ADAPTOR OPTIONS, GUN DIMENSIONS AND
FIXING LOCATIONS - SEE PAGES 22, 23 & 24

REMOVABLE SEAL FINE FINISH TIP SELECTION CHART

PART No.	ORIFICE		FAN LENGTH*		FLOW [WATER @ 500 psi/35 bar]		REPLACABLE SEAL
	INCH	MM	INCH	MM	US GPM	L/MIN	
RS-0909-F	0.009	0.23	10	254	0.039	0.15	RS-5858-K5
RS-0911-F	0.009	0.23	12	305	0.039	0.15	
RS-1109-F	0.011	0.28	8	203	0.06	0.23	RS-5859-K5
RS-1111-F	0.011	0.28	10	254	0.06	0.23	
RS-1113-F	0.011	0.28	12	305	0.06	0.23	
RS-1115-F	0.011	0.28	14	356	0.06	0.23	
RS-1309-F	0.013	0.33	10	254	0.09	0.34	RS-5860-K5
RS-1311-F	0.013	0.33	12	305	0.09	0.34	
RS-1313-F	0.013	0.33	14	356	0.09	0.34	
RS-1315-F	0.013	0.33	16	406	0.09	0.34	
RS-1509-F	0.015	0.38	10	254	0.12	0.45	RS-5861-K5
RS-1511-F	0.015	0.38	12	305	0.12	0.45	
RS-1513-F	0.015	0.38	14	356	0.12	0.45	
RS-1515-F	0.015	0.38	16	406	0.12	0.45	
RS-1517-F	0.015	0.38	18	457	0.12	0.45	
RS-1709-F	0.017	0.43	10	254	0.16	0.61	RS-5862-K5
RS-1711-F	0.017	0.43	12	305	0.16	0.61	
RS-1713-F	0.017	0.43	14	356	0.16	0.61	
RS-1715-F	0.017	0.43	16	406	0.16	0.61	
RS-1717-F	0.017	0.43	18	457	0.16	0.61	

* FAN LENGTH BASED ON 1000 psi [70 bar] WATER, SPRAYED AT 12" [300mm] FROM SURFACE.

ACTUAL RESULTS MAY VARY, DEPENDING ON MATERIAL VISCOSITY

BEFORE ORDERING SPARE SEALS, CHECK FOR THE CORRECT PART NUMBER IN THE TABLE ABOVE

REMOVABLE SEAL STANDARD TIP SELECTION CHART

PART No.	ORIFICE		FAN LENGTH*		FLOW [WATER @ 500 psi/35 bar]	
	INCH	MM	INCH	MM	US GPM	L/MIN
RS-0702	0.007	0.18	2	51	0.028	0.11
RS-0704	0.007	0.18	4	102	0.028	0.11
RS-0706	0.007	0.18	6	152	0.028	0.11
RS-0708	0.007	0.18	8	203	0.028	0.11
RS-0902	0.009	0.23	2	51	0.039	0.15
RS-0904	0.009	0.23	4	102	0.039	0.15
RS-0906	0.009	0.23	6	152	0.039	0.15
RS-0908	0.009	0.23	8	203	0.039	0.15
RS-0910	0.009	0.23	10	254	0.039	0.15
RS-0912	0.009	0.23	12	305	0.039	0.15
RS-1104	0.011	0.28	4	102	0.06	0.23
RS-1106	0.011	0.28	6	152	0.06	0.23
RS-1108	0.011	0.28	8	203	0.06	0.23
RS-1110	0.011	0.28	10	254	0.06	0.23
RS-1112	0.011	0.28	12	305	0.06	0.23
RS-1114	0.011	0.28	14	356	0.06	0.23
RS-1304	0.013	0.33	4	102	0.09	0.34
RS-1306	0.013	0.33	6	152	0.09	0.34
RS-1308	0.013	0.33	8	203	0.09	0.34
RS-1310	0.013	0.33	10	254	0.09	0.34
RS-1312	0.013	0.33	12	305	0.09	0.34
RS-1314	0.013	0.33	14	356	0.09	0.34
RS-1316	0.013	0.33	16	406	0.09	0.34
RS-1506	0.015	0.38	6	152	0.12	0.45
RS-1508	0.015	0.38	8	203	0.12	0.45
RS-1510	0.015	0.38	10	254	0.12	0.45
RS-1512	0.015	0.38	12	305	0.12	0.45
RS-1514	0.015	0.38	14	356	0.12	0.45
RS-1516	0.015	0.38	16	406	0.12	0.45
RS-1518	0.015	0.38	18	457	0.12	0.45

PART No.	ORIFICE		FAN LENGTH*		FLOW [WATER @ 500 psi/35 bar]	
	INCH	MM	INCH	MM	US GPM	L/MIN
RS-1706	0.017	0.43	6	152	0.16	0.61
RS-1708	0.017	0.43	8	203	0.16	0.61
RS-1710	0.017	0.43	10	254	0.16	0.61
RS-1712	0.017	0.43	12	305	0.16	0.61
RS-1714	0.017	0.43	14	356	0.16	0.61
RS-1716	0.017	0.43	16	406	0.16	0.61
RS-1718	0.017	0.43	18	457	0.16	0.61
RS-1906	0.019	0.48	6	152	0.19	0.72
RS-1908	0.019	0.48	8	203	0.19	0.72
RS-1910	0.019	0.48	10	254	0.19	0.72
RS-1912	0.019	0.48	12	305	0.19	0.72
RS-1914	0.019	0.48	14	356	0.19	0.72
RS-1916	0.019	0.48	16	406	0.19	0.72
RS-1918	0.019	0.48	18	457	0.19	0.72
RS-2110	0.021	0.53	10	254	0.24	0.91
RS-2112	0.021	0.53	12	305	0.24	0.91
RS-2114	0.021	0.53	14	356	0.24	0.91
RS-2116	0.021	0.53	16	406	0.24	0.91
RS-2118	0.021	0.53	18	457	0.24	0.91
RS-2410	0.024	0.61	10	254	0.31	1.17
RS-2412	0.024	0.61	12	305	0.31	1.17
RS-2414	0.024	0.61	14	356	0.31	1.17
RS-2416	0.024	0.61	16	406	0.31	1.17
RS-2418	0.024	0.61	18	457	0.31	1.17
RS-2710	0.027	0.69	10	254	0.385	1.46
RS-2712	0.027	0.69	12	305	0.385	1.46
RS-2714	0.027	0.69	14	356	0.385	1.46
RS-2716	0.027	0.69	16	406	0.385	1.46
RS-2718	0.027	0.69	18	457	0.385	1.46

* X369FAN LENGTH BASED ON 1000 psi [70 bar] WATER, SPRAYED AT 12" [300mm] FROM SURFACE.

REPLACEMENT TIP SEALS FOR STANDARD TIPS: RS-5000-K5 MULTI-PACK OF 5 PIECES / RS-5000-K10 MULTI-PACK OF 10 PIECES

TYPICAL CONNECTION SCHEMATIC

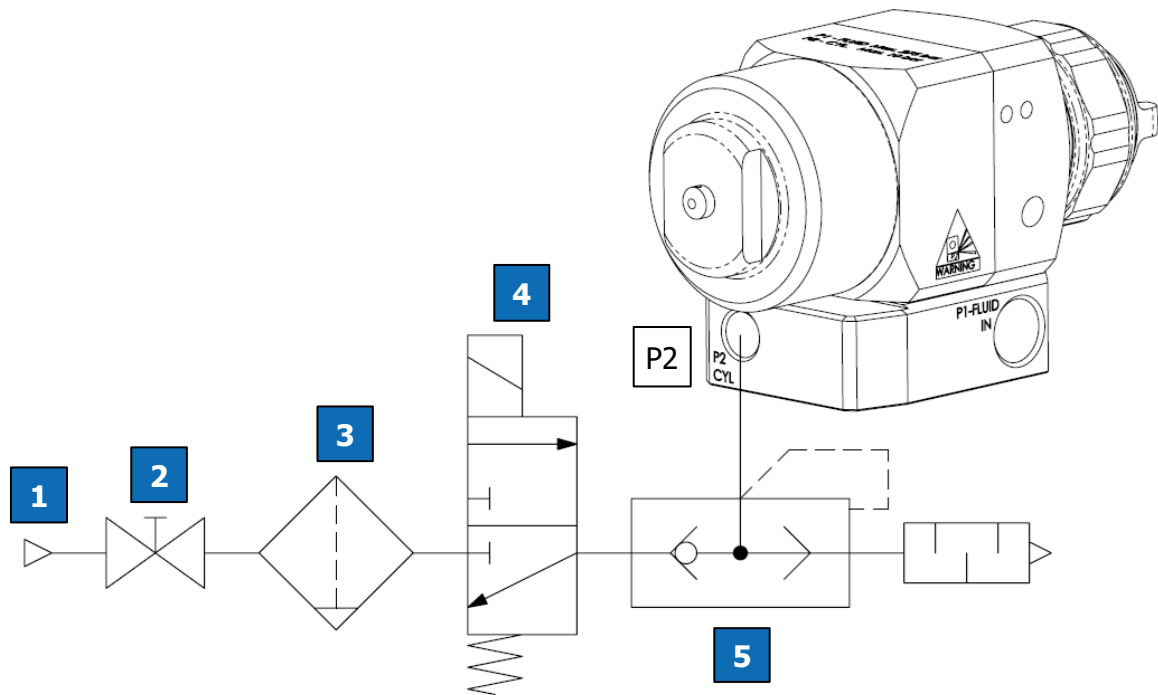

1	Compressed air take-off
2	Shut-off valve
3	Air filter
4	3/2 solenoid valve, normally closed
5	Quick exhaust valve & silencer
P2	CYL - 1/8" NPS(F)

**WARNING**

The spray gun must be earthed to dissipate any electrostatic charges which may be created by fluid or air flows.

This can be achieved through the spray gun mounting, or conductive air/fluid hoses.

Electrical bond from the spray gun to earth should be checked and a resistance of less than 10^6 Ohms is required.

TYPICAL FLUID CONNECTION SCHEMATIC

AG364-XXXX-S
FRONT VIEW

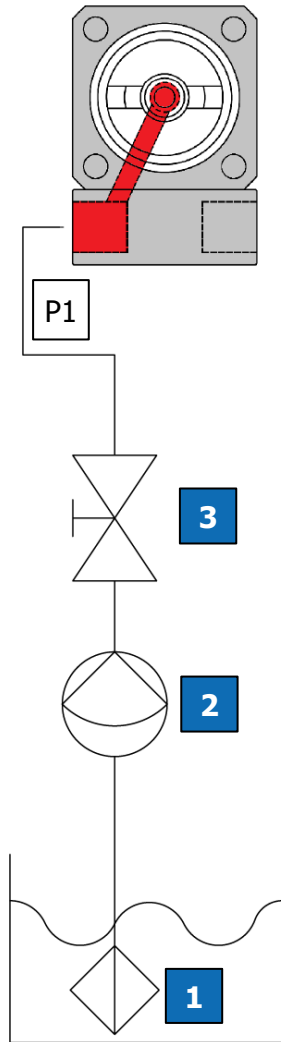

AG364-XXXX-T
FRONT VIEW

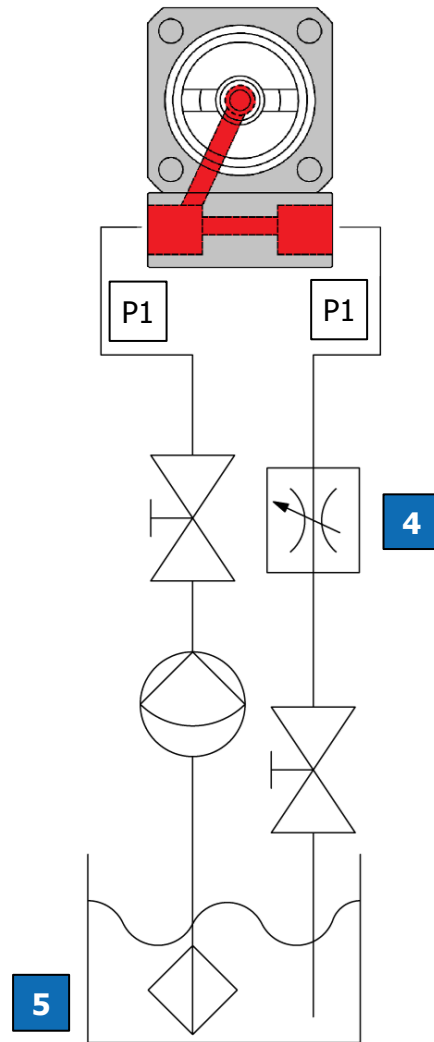

1	Fluid filter
2	Fluid supply
3	Shut-off valve
4	Fluid restrictor valve
5	Fluid reservoir
P1	Fluid - 1/4" NPS

NOTE

Protective coatings have been used for storage protection.

Flush the equipment fluid passageways with appropriate solvent before use.

SPRAY GUN AND MANIFOLD INSTALLATION

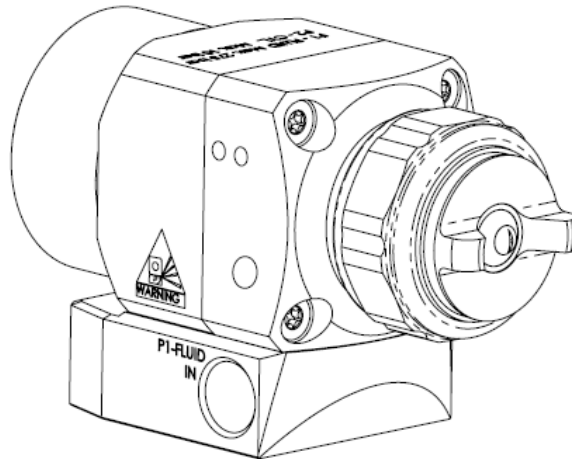
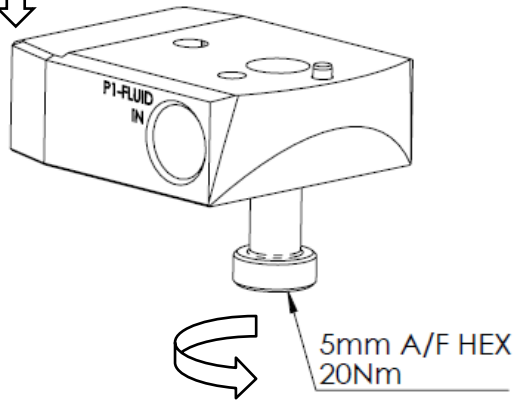
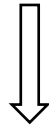
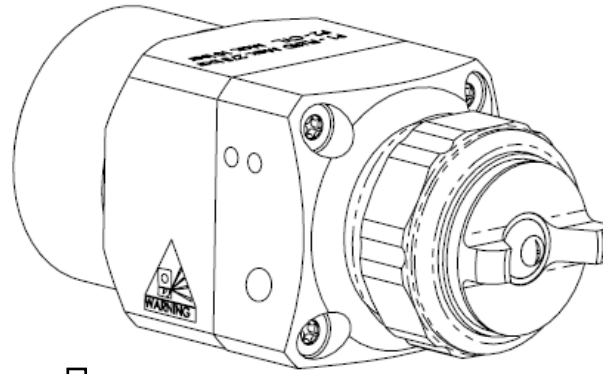

EXPLODED VIEW

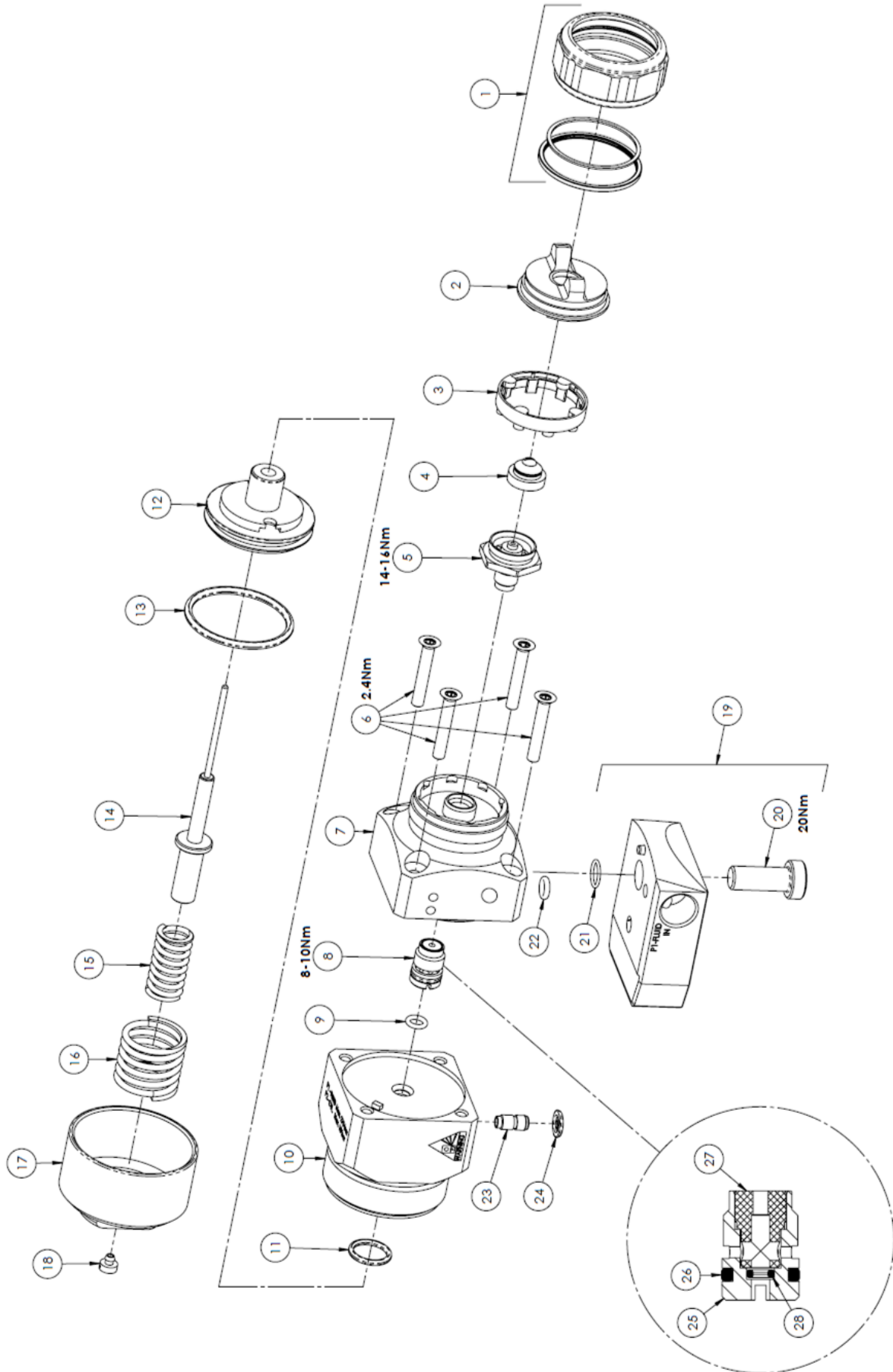

PARTS LIST

REF.	PART No.	DESCRIPTION	ASSEMBLY QTY.
1 #	54-6029-K	RETAINING RING WITH SEALS	1
2 #	54-6031-K	TIP HOLDER	1
3	SPA-70-K10	INDEX PLATE (KIT OF 10)	1
4	SEE TABLE	FLUID TIP	1
5 #	SPA-69-K	NEEDLE SEAT ASSY	1
6	S-14190-K4	TORX SCREW (KIT OF 4)	1
7	SPA-190-K	SPRAYHEAD	1
8 * #	SPA-76-K	NEEDLE PACKING	1
9 *	S-28219X-K4	O RING (KIT OF 4)	1
10	SPA-191-K	BODY	1
11 *	S-28220X-K2	O RING (KIT OF 2)	1
12 #	SPA-68-K	PISTON	1
13 * #	SPA-45X-K2	O RING (KIT OF 2)	1
14	SPA-79	FLUID NEEDLE	1
15 #	SPA-77	NEEDLE SPRING	1
16 #	SPA-13	PISTON SPRING	1
17	SPA-67-BL-K	END CAP	1
18	SPA-54	VENT CAP	1
19	SPA-428-K	SCREW MANIFOLD ASSEMBLY	1
	SPA-428U-K	RECIRCULATION SCREW MANIFOLD ASSEMBLY	
20 #	SPA-161-K2	CLAMPING SCREW (KIT OF 2)	1
21 #	-	O-RING (PART OF SPA-161-K2)	1
22 *	SN-71X-K2	O RING	1
23 #	SPA-52	AIR TUBE	1
24 *	S-28223X-K4	O RING (KIT OF 4)	1
25	-	HOUSING	1
26	SPA-29X-K4	O RING (KIT OF 4)	1
27	SPA-96-K4	SEAL	1
28	SPA-46X-K4	O RING (KIT OF 4)	1

SERVICE PARTS

KK-4588	SOFT SEAL SERVICE KIT - INCLUDES ITEMS MARKED *
KK-4589	MAJOR OVERHAUL SERVICE KIT - INCLUDES ITEMS MARKED #

TYPICAL SETTING

1. There is no air used by this spray gun to influence atomisation and fan pattern size. The fluid pressure and selection of spray tip controls these spray parameters.
2. Select a suitable spray tip based upon the information contained in the tables on page 11 and 12 and fit it securely onto the spray gun.
3. There is limited control of fluid flow using pump pressure and tip orifice size.

TYPICAL START-UP SEQUENCE

1. Select a nominal gun fluid inlet pressure to start the spray optimisation [eg 500psi/33 bar] by adjusting pump pressure or fluid regulator output pressure
2. View the spray pattern appearance and increase or decrease fluid pressure to establish the minimum fluid pressure at which a well shaped spray pattern can be achieved without poor atomisation 'tails' .
3. Test spray products and increase fluid pressure until the required results are achieved.
4. If maximum fluid pressure is reached and more fluid flow is required, then increase tip orifice size and repeat steps 1-3
5. Remember - To change fluid flow, coating thickness, spray pattern length etc could require modification of fluid viscosity, tip orifice size, tip pattern angle, pump pressure and gun traverse speed

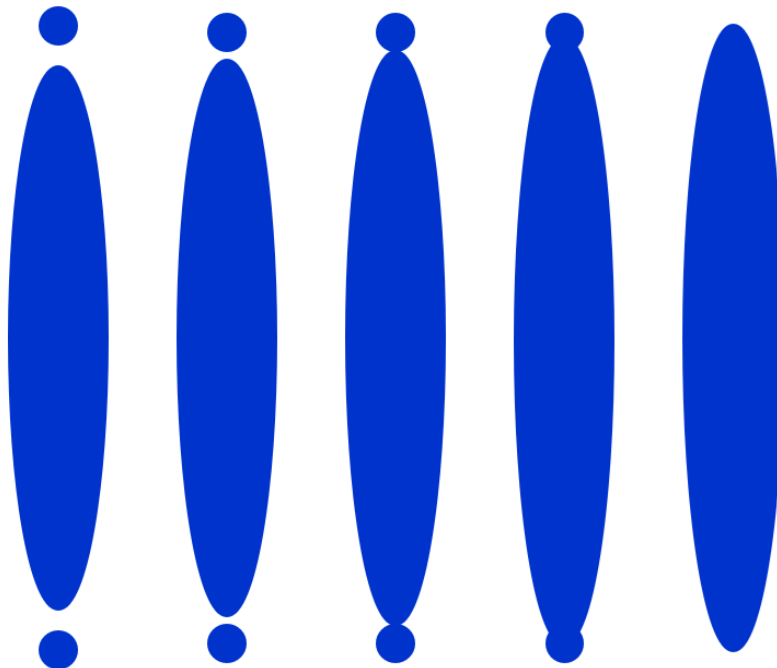

SPRAY GUN MAINTENANCE

KEY - MAINTENANCE SYMBOLS	
	Order for disassembly <i>(reverse for assembly)</i>
#	Item Number
	Petroleum Grease/Jelly

DISASSEMBLY - NEEDLE SEAT & NEEDLE

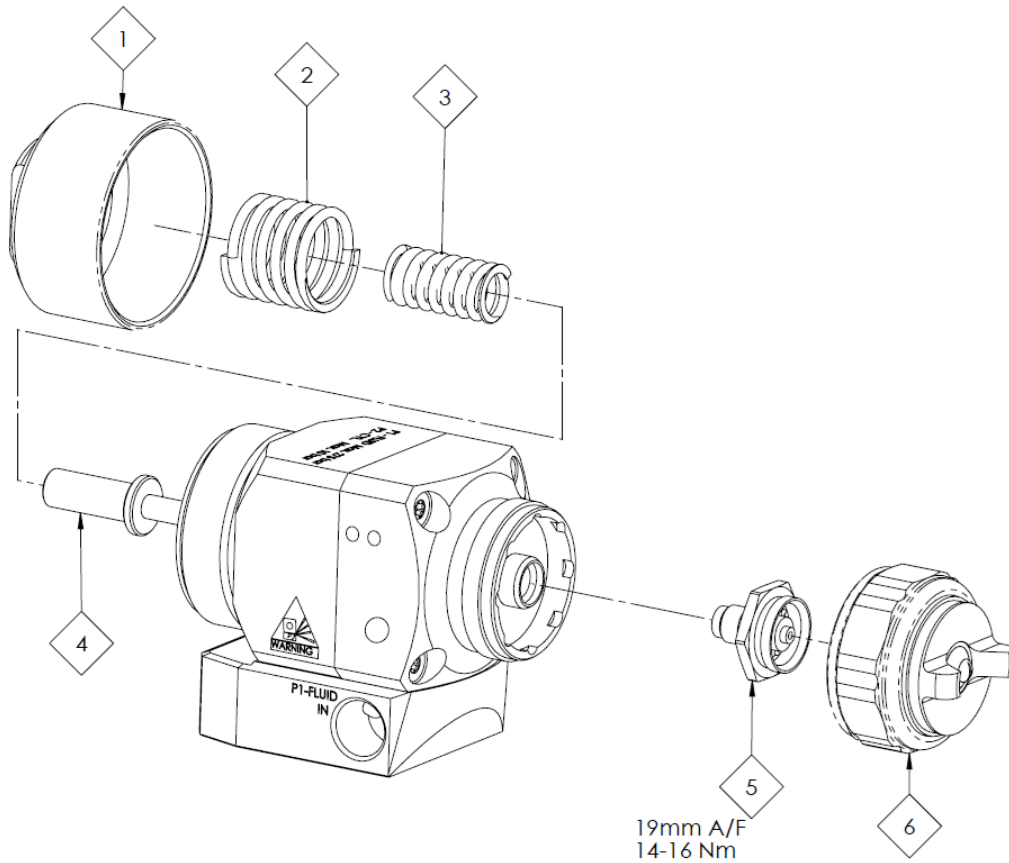

DISASSEMBLY - TIP HOLDER, NEEDLE SEAT & INDEX PLATE

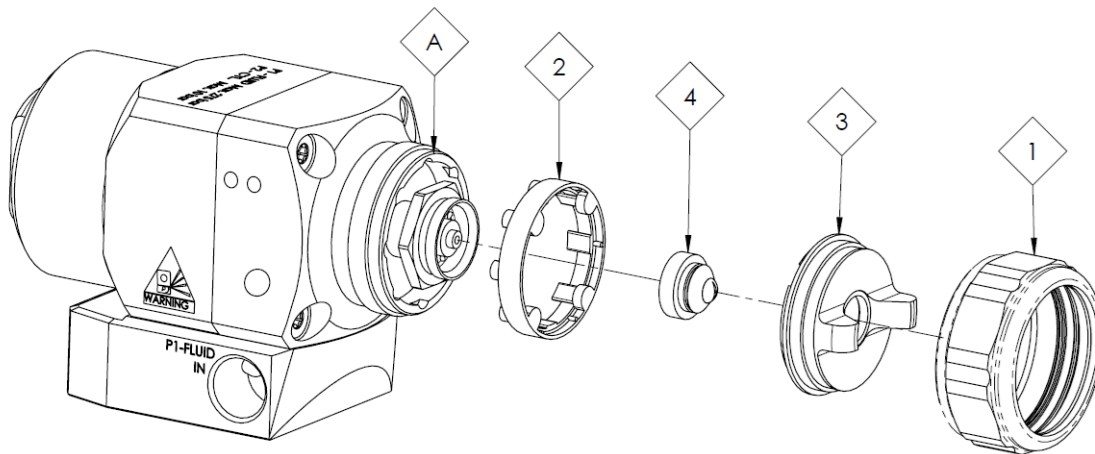

By combined use of gun assembly A and item 2, the tip holder and tip can be indexed at 45° rotational increments.

Item 2 can also be removed and not used, allowing free rotation to any angle.

DISASSEMBLY - PISTON

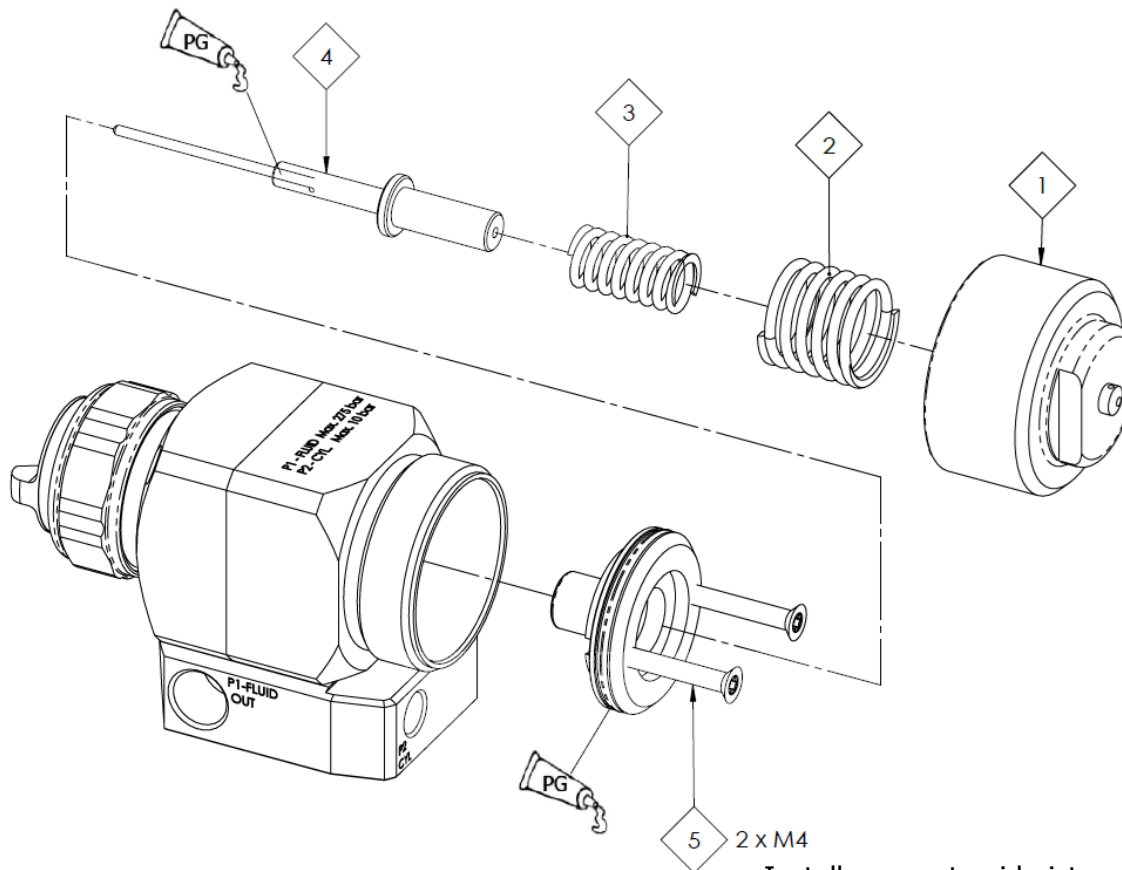

Install screws to aid piston removal.

DISASSEMBLY - NEEDLE PACKING

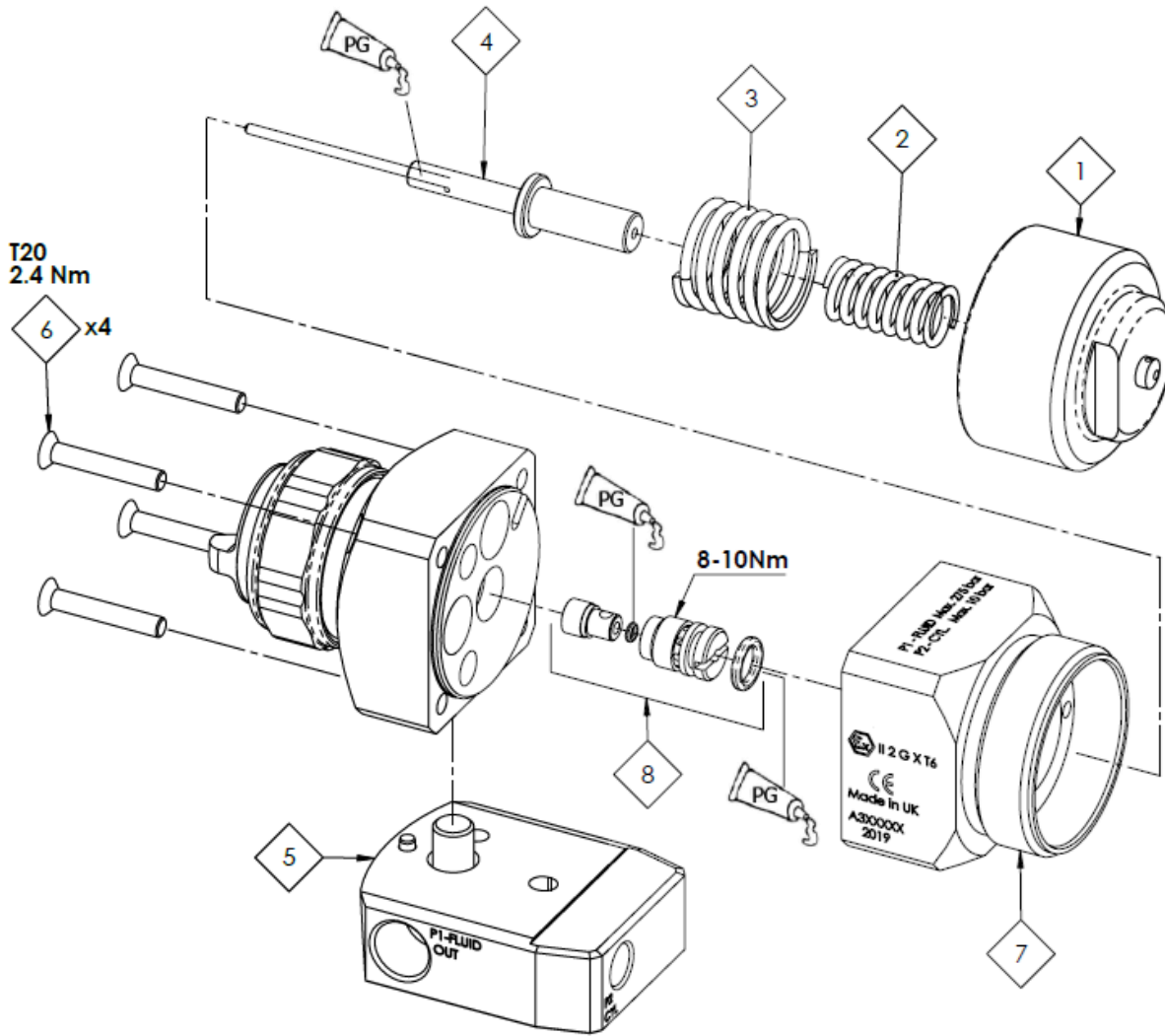

TROUBLESHOOTING MECHANICAL PERFORMANCE

GENERAL FAULTS	CAUSE	CORRECTION
Will not spray.	No cylinder air pressure at gun.	Check air supply and air line.
	Blocked tip.	Replace or clean.
	Insufficient piston (CYL) air pressure	Check air supply and air line pressure.
	Damaged or missing piston O ring	Inspect and/or replace
Gun will not shut off.	Fluid pressure above gun max working pressure.	Reduce fluid pressure.
	Air pressure to piston is not being removed	Use correct solenoid valve for CYL air or fit quick exhaust valve

FLUID LEAKAGE FAULTS	CAUSE	CORRECTION
Slow fluid leak from needle seat.	Needle seat internal surface scored damaged or worn.	Replace.
	Fluid needle external profile damaged or worn.	Replace.
	Contamination on needle or seat mating surfaces preventing good seal.	Thoroughly clean.
Major fluid leak or fluid jetting from fluid tip or needle seat, when gun is off.	Contamination on needle or seat mating surfaces preventing good seal.	Remove tip and needle and thoroughly clean.

FLUID FAULTS	CAUSE	CORRECTION
<p>Slow fluid leak from needle packing, three possible places.</p> 	Fluid needle packing worn or loose.	Tighten or replace as necessary.

ASSEMBLY FAULTS	CAUSE	CORRECTION
Spray gun is loose when assembled onto manifold.	Clamping screw has not been tightened.	Tighten screw.
	Clamping screw has worn.	Replace using clamping screw kit SPA-161-K2.
Spray Gun does not fit onto manifold easily before the screw is tightened.	Damage to head of Manifold Location Pin.	Check pin. Repair or replace.
Spray Gun does not remove from manifold easily after the screw is undone.	Damage to head of Manifold Location Pin.	Check pin. Repair or replace.

SCREW TYPE MANIFOLD FAULTS	CAUSE	CORRECTION
Air leak between gun and manifold when gun is triggered.	CYL Air Tube O ring damaged or missing.	Replace O ring.
Fluid leak between gun and manifold.	Fluid passageway O ring damaged or missing.	Replace O ring.

TROUBLESHOOTING SPRAY PERFORMANCE	CAUSE	CORRECTION
Gun spits paint when triggering on due to paint build-up inside air cap between spraying operations.	Needle seat not fitted correctly in gun head.	Tighten.
	Needle seat/needle leakage.	Check for damage or blockage.
Tip retainer fills with paint when triggered.	Tip not seated correctly.	Remove, clean and reinstall tip into gun head.
	Tip seat worn in rear of tip.	Replace seat.
	Needle seat not tight.	Tighten.
Paint build-up on fluid tip.	Coating type promotes build-up.	Consult coating supplier.
	Damaged or partially blocked tip.	Check for damage or blockage.
Paint build-up on tip retainer.	Damaged or partially blocked tip.	Replace or thoroughly clean tip and cap.
	Gradual build-up of bounce-back on gun head.	Thoroughly clean gun head. Examine spray process to reduce spray fog.

TROUBLESHOOTING SPRAY PERFORMANCE

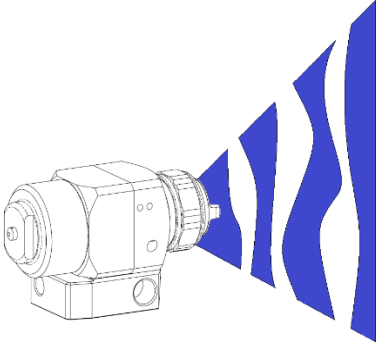
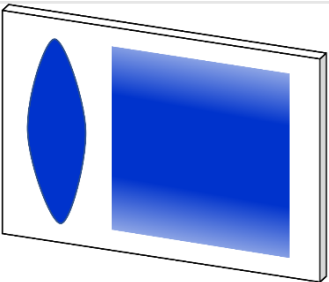
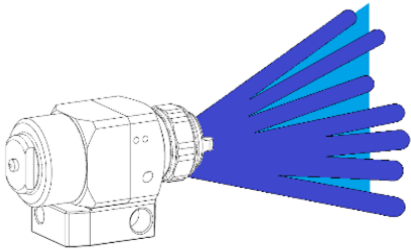
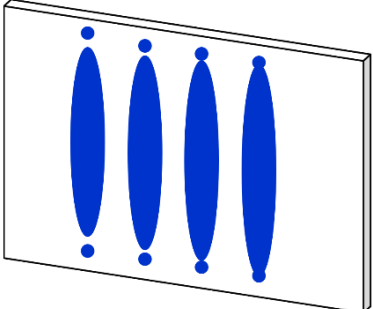
SPRAYING FAULTS	CAUSE	CORRECTION
Intermittent or 'fluttering' spray fan. 	Air in paint supply line.	Check and tighten pump siphon hose connections.
		Bleed air from supply line.
	Partially obstructed fluid passage or hose.	Clean or replace.
Heavy centre pattern. 	Fluid Tip worn	Replace.
	Fluid Viscosity too low	Change tip.
Unatomised multiple jets. 	Tip partially blocked	Clean or replace.
	Viscosity too high	Reduce viscosity
Top and bottom 'Tails' 	Viscosity too high	Reduce viscosity
	Insufficient Fluid Flow	Increase pump pressure
	Tip orifice too big	Change to smaller tip

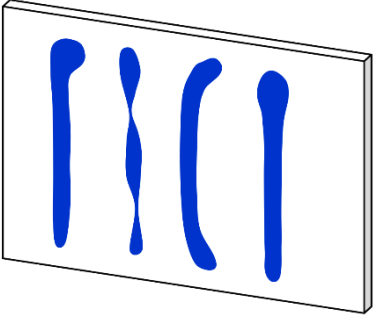
SPRAYING FAULTS	CAUSE	CORRECTION
Distorted spray pattern shape 	Worn or partially blocked tip	Clean and inspect, , replace if necessary
Runs and sags.	Too much material.	Reduce tip size or reduce fluid pressure.
	Material too thin.	Apply light coats/reduce fluid flow.
	Gun tilted at an angle.	Mount gun at right angle to work.
Thin, sandy coarse finish drying before it flows out.	Gun too far from surface.	Check distance.
	Fluid flow too low.	Increase fluid flow by increasing fluid tip size or supply pressure.

MOUNTING ADAPTOR OPTIONS - SCREW TYPE MANIFOLD

SPA-173-K

Horizontal mounting bar and screws.

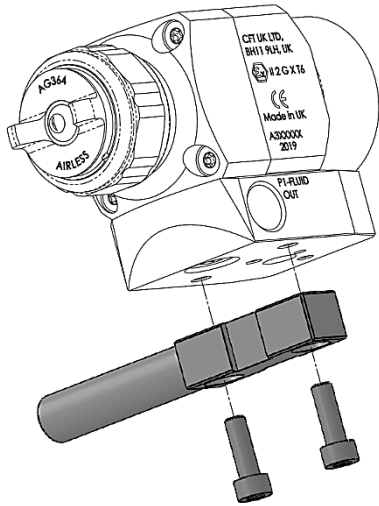

SPA-174-K

Vertical mounting bar and screws

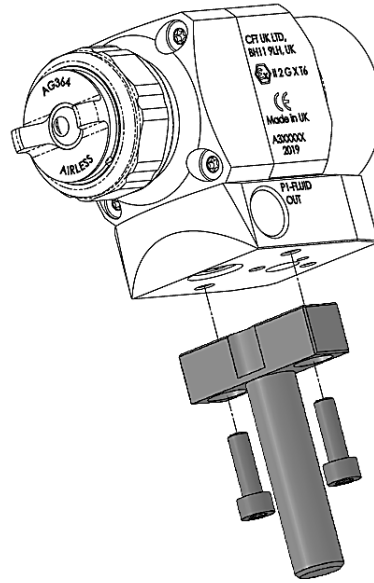

Bar diameter = 12.5mm (to fit into 1/2" Hole)

SPA-175-K

Mounting block and screws

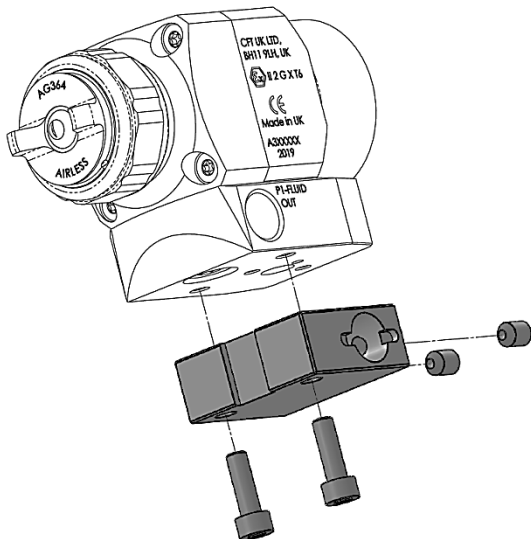

Hole Diameter = 12.8mm (to take 1/2" diameter bar)

SPA-176-K

Index adjustment and screws

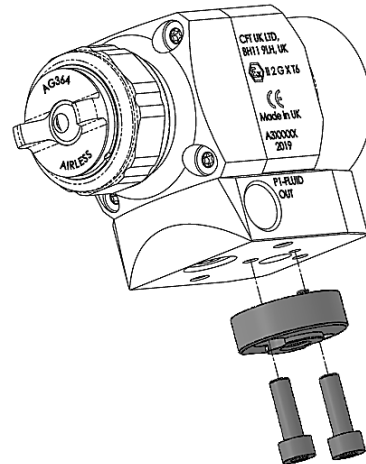

Mounting Arm available from Machine Manufacturer



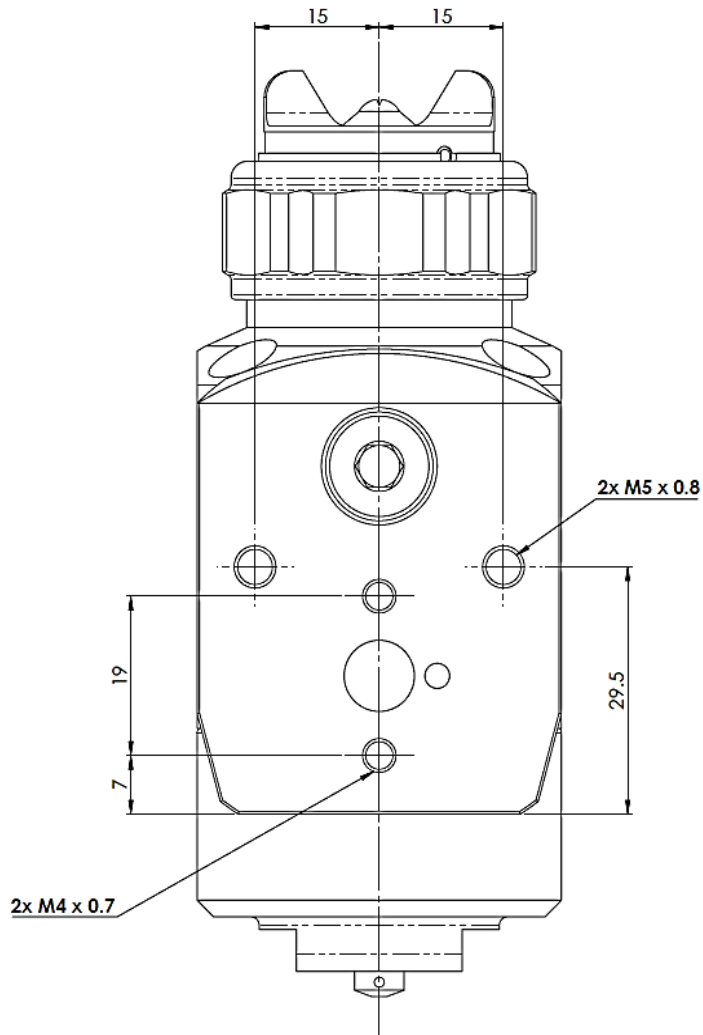

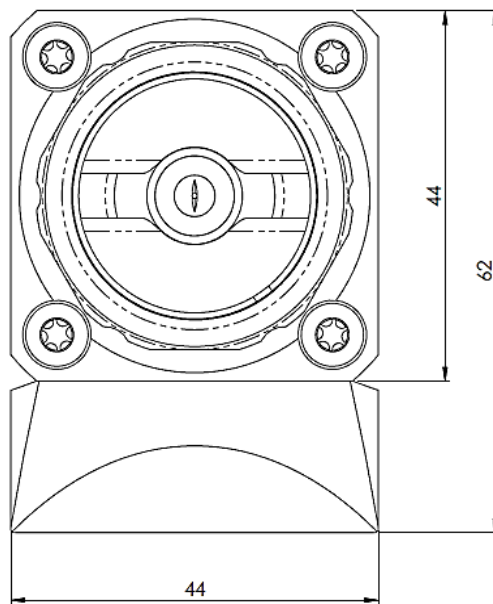
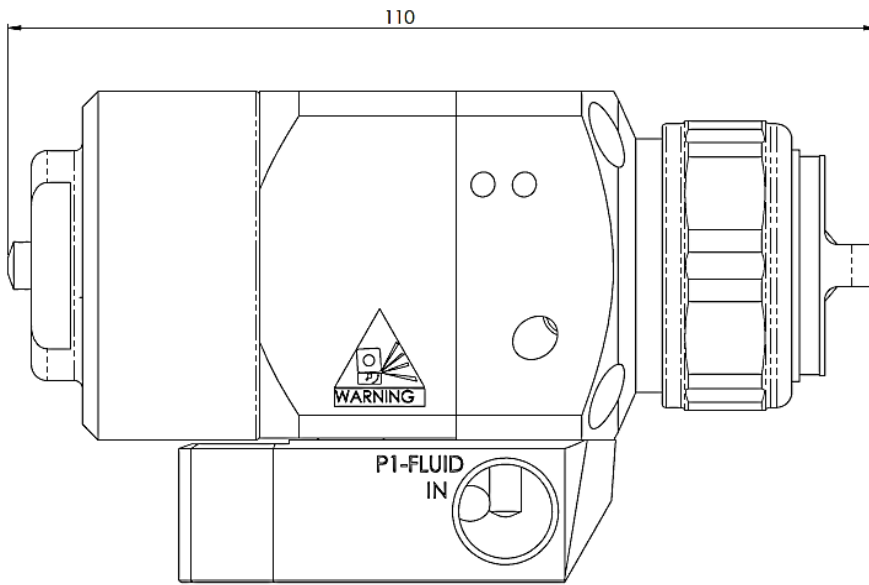

FIXING LOCATIONS

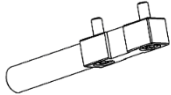

DIMENSIONS



ACCESSORIES

PART No.	DESCRIPTION		
SPA-173-K	Horizontal mounting bar and screws.		
SPA-174-K	Vertical mounting bar and screws		
SPA-175-K	Mounting block and screws		
SPA-176-K	Index adjustment and screws		
SPA-115	1/4" NPT- NPS Elbow 275 bar MWP.		
SPA-116	1/4" NPT - BSP Elbow 275 bar MWP.		
72-2341	Housing & filter	Filter 1/4" NPS M-F 100 Micron 400 bar.	
54-1835	Filter element		
DSG-4003	Tip cleaners (KIT OF 12)		

WARRANTY POLICY

This product is covered by Binks materials and workmanship limited warranty.

The use of any parts or accessories, from a source other than Binks, will void all warranties. Failure to reasonably follow any maintenance guidance provided, may invalidate any warranty.

For specific warranty information please contact Binks.

For technical assistance or to locate an authorised distributor, contact one of our international sales and customer support locations below.

REGION	BINKS CONTACT
Americas	Tel: 1-888-992-4657
Europe, Africa, Middle East	Tel: +44 (0)1202 571 111
India	marketingroa@binks.com
China	Tel: +8621-3373 0108
Korea	Tel: +82313663303
Japan	Tel: +81 45 785 6421
Australia	Tel: +61 (0) 2 8525 7555

WARRANTY PAGE



Binks

Binks is a global leader in innovative finishing technologies. Binks reserves the right to modify equipment specifications without prior notice.

Binks®, DeVilbiss®, and Ransburg® are registered trademarks of Binks US, LLC.